

Installation Guide

Internal Head Restraints

IHR Internal Head Restraints

The Ancon IHR is designed to restrain the top of internal walls or the top of the inner leaf of a cavity wall. It comprises an L-shaped channel stem and a top section available in a variety of designs to suit different fixing methods and substrates; the top section slides in the channel to accommodate vertical movement between the blockwork and the structure.

Channel Stem

The channel stem is closed at the front to prevent mortar ingress.

The standard height of an IHR will suit a 215mm block. Other stem lengths are also available to suit cut blocks with a minimum height of 150mm.



Sliding Top Section

The IHR sliding top section is available in two standard lengths; one length to accommodate a gap of up to 50mm, and another to accommodate gaps of 51-75mm.

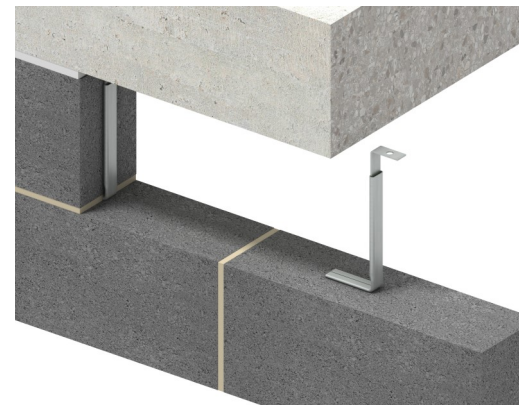
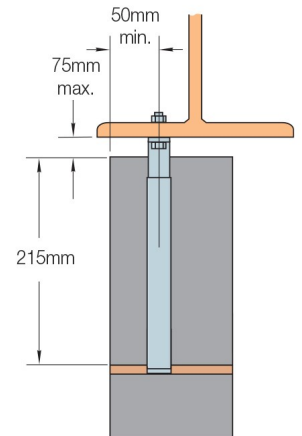

Positioning

The horizontal leg of the lower section, should be placed directly on top of the block below. The vertical joint should be filled with mortar each side of the stem. IHR's should ideally be positioned centrally in the width of the wall, where this is not possible the centre of the stem should be at least 50mm from the edge of the wall.

IHR Head Restraints will typically be positioned at 450mm or 900mm centres depending on the expected load at the top of the wall. The table provides the design resistance per metre for the IHR range when installed with a 25mm, 50mm and 75mm gap.

Fixings

The sliding tie is provided with either a hole (IHR - B) or slot (IHR - V) to suit M8 bolts, a hole (IHR-S) to suit a SDTSS-38-5PT self-tapping screw, a notch end (IHR-C) to fix directly into a 38/17 or 30/20 cast-in channel or a notch end (IHR-H) to suit the Ancon Hammer-On Section that attaches to a 6.8mm - 25mm steel flange without site drilling.

Ancon IHR-B
with 9mm
dia. hole

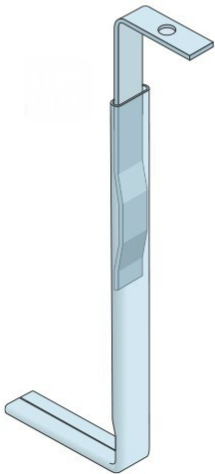

Ancon IHR-V
with 9mm x
25mm slot

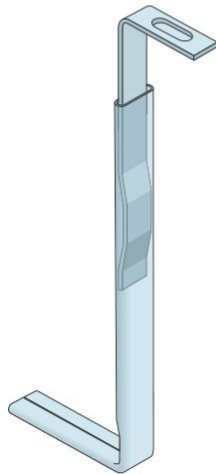

Ancon IHR-S
with 6mm
dia. hole

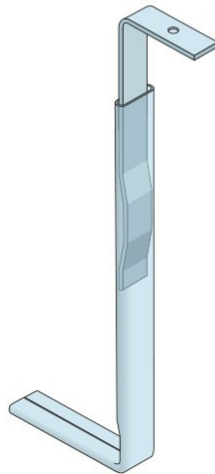

Ancon IHR-H
supplied with
Hammer-On
Section

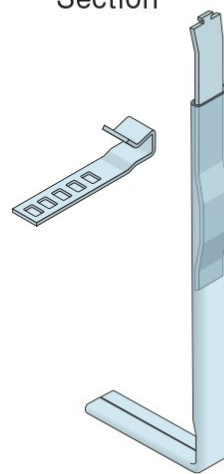

Ancon IHR-C
to suit cast-in
channel

IHR - C 38
to suit 38/17
IHR - C 30
to suit 30/20



Before Installation

Check that the IHR ordered and supplied meets the dimensions and performance specifications of your application.

		Full Blocks (215mm)			Cut Blocks (min. 150mm)		
Product Reference	Spacing	25mm Gap	50mm Gap	75mm Gap	25mm Gap	50mm Gap	75mm Gap
IHR-B, IHR-V, IHR-C and IHR-S	900mm	1.78kN/m	1.22kN/m	1.06kN/m	1.44kN/m	0.99kN/m	0.86kN/m
	450mm	3.56kN/m	2.44kN/m	2.11kN/m	2.89kN/m	1.99kN/m	1.72kN/m
IHR-H	900mm	1.13kN/m	1.13kN/m	1.06kN/m	0.46kN/m	0.46kN/m	0.43kN/m
	450mm	2.27kN/m	2.27kN/m	2.11kN/m	0.92kN/m	0.92kN/m	0.86kN/m

Safety Precautions

Ancon stainless steel products are produced from sheared plate. As with all such industrial fabrications, these may present sharp edges. **Suitable personal protective equipment should be worn at all times during handling and installation.**

The Construction applications and details provided in this guide are indicative only. In every case installation should be entrusted to appropriately qualified and experienced persons. Normal handling precautions should be taken to avoid physical injury. The company cannot be held responsible for any injury as a result of using our products, unless such injury arises as a result of our negligence.

© Protected by copyright